Excursion 13 Rosneath Peninsula and Loch Long

Key details

Author	P.W.G. Tanner
Themes	To examine the small-scale, mainly tectonic, structures in the Dalradian rocks immediately north of the Highland Boundary Fault and show how they can be used to deduce the geometry and relative ages of two of the largest fold structures in the UK: the Tay Nappe (D_1/D_2) and the Downbend antiform (D_4).
Features	Dalradian greywackes, slates and phyllites; way-up structures; identification and geometry of a great variety of minor folds, lineations, and cleavages (especially those resulting from pressure-solution processes); progressive development and overprinting of one set of minor structures upon another; minor intrusions; glacial features.
Maps	O.S. 1:50 000 Sheets 56 Loch Lomond and 63 Firth of Clyde. B.G.S 1:50 000 Sheets 30W Greenock and 38W Ben Lomond 1:63 360 Sheets 29 Rothesay and 30 Glasgow
Terrain	Coastal sections, mainly exposed to the prevailing SW wind: often slippery underfoot.
Distance and Time	The driving distance from Locality 1 to Locality 8 is about 22 km (13 miles), all on good roads. Examination of the Portincaple sections involves 1.5 km of easy walking. Allow 6 hours for this excursion, preferably starting at Locality 1 some 2–3 hours after high tide.
Short	If the tide is unsuitable, or if it is intended to link this itinerary excursion with a visit to the A82 Loch Lomond road sections (see Excursion 11), brief visits to localities 1, 4 and 6 are recommended.
Access	The section at Locality 1 is best examined at low tide and certainly within the period between 3 hours after high tide (HT) and 3 hours before the succeeding HT. All of the remaining sections are accessible (and more comfortable to work on) in the period between 2 hours after HT and 2 hours before the next one.

Beware slippery rocks: those at Localities 1, 4 and 6 are particularly treacherous when it is raining.

You are advised not to stop on the Ministry of Defence (MOD) road north from Coulport (Figure 13.1) nor on the road over Peaton Hill a few kilometres to the SE as these areas are under constant MOD surveillance.

NOTE: there are public toilets in Kilcreggan, just to the west of the pier, with sufficient parking space for coaches.

Introduction

The excursion consists of a south-to-north traverse across the Dalradian rocks of the Southern Highland Group (Figure 13.1). Starting at the Highland Boundary Fault, the traverse crosses the regional 'Steep Belt', which contains the hinge zone of the Tay Nappe, and then continues across the Downbend Antiform and into the 'Flat Belt' (Figure 13.2). The Tay Nappe, which in this area is represented by the downward-facing Aberfoyle Anticline (Shackleton 1958), developed

during the first deformation (D_1) to affect the Dalradian rocks, prior to 590 Ma ago (Rogers et al., 1989). It is folded around a much younger structure, the Downbend Antiform, which is of D_4 age and probably formed at around 460–440 Ma ago (Harte et al., 1984)

The Tay Nappe is generally considered to have been a flat-lying structure prior to D_4 and have been bent into its present attitude in the 'Steep Belt' by the Downbend Antiform. Thus a traverse northwards from the Highland Boundary Fault along the present ground surfaces takes us from the rocks which were originally at a high structural level on the upper limb of the Tay Nappe, to rocks at a lower structural level on the inverted limb of the nappe around Portincaple. Prior to D_4 , the latter were some 7–9 km deeper in the crust (Figure 13.2) than rocks now seen at the Highland border.

Along this traverse, we can therefore examine a progression from rocks which have only been deformed once (D_1) and which show a single set of folds with an axial-planar cleavage (Locality 1, (Figure 13.3)) to rocks at a deeper level in the nappe which have been affected by a later folding (D_2) (Locality 2, (Figure 13.3) ; (Figure 13.5)), and which develop a penetrative D_2 fabric which overprints (Localities 3 & 4, (Figure 13.3) ; (Figure 13.6)b, and in some cases obliterates, the D_1 cleavage. Farther north along the section, between Localities 5 & 6 (Figure 13.3) a further deformation (D_3) affects the rocks and the D_2 microlithons (seen as parallel-sided stripes on the rock surface bounded by D_2 cleavage surfaces and containing the microfolded D_1 fabric, see Figure 7) are deformed by D_3 minor folds. These folds are characterized by having a Z-shaped profile when viewed down the plunge of the fold hinge towards the east (i.e. they verge consistently southwards), and are not known to be associated with any major folds in the area. Finally, in the vicinity of the D_4 Downbend (Localities 6–8, (Figure 13.3)), minor D_4 folds become common: their vergence is related to their position within the structure and they give rise to complex fold interference patterns.

The oncoming of the D_2 , D_3 and D_4 deformations occurs in sequence from south to north (Figure 13.3), as is well shown for the adjoining area to the east by Mendum and Fettes (1985) and in the series of synoptic structural maps on BGS Sheet 38W (Loch Lomond). Bedding in the finer-grained rocks is progressively destroyed northwards along the Rosneath-Loch Long section, largely by pressure-solution processes, but is still recognizable at the deepest levels in areas of low-strain and where the rocks are especially competent and thick-bedded. Metamorphic grade is low throughout the section, but grain size increases northwards, the rocks become increasingly recrystallized, and biotite is developed in rocks north of the Downbend. Quartz-carbonate+ chlorite veins form at all stages of the deformation sequence from syn- D_1 to post- D_4 , the early veins being subsequently deformed in rocks found in the more northerly part of the section. Quartz veining increases in abundance from south to north.

Roberts (1977) has published an excursion guide to the Dalradian rocks of Rosneath and south-east Cowal which provides a summary of the stratigraphy and structure and gives brief descriptions of localities in the Rosneath-Loch Long area which are largely alternative to those described here. D_1 (this account) = B_1 (Roberts); $D_2 = B_{2a}$; $D_3 + D_4 = B_{2b}$. Accounts of the stratigraphy and structure of Dalradian rocks in other parts of the Highland Border zone are given by Shackleton (1958), Harris et al. (1976), Bradbury et al. (1979), Harte et al. (1984), and Mendum & Fettes (1985).

The aim here is to provide a well-illustrated guide to a few carefully chosen localities which together demonstrate the sequence of development of minor structures and fabrics in the Dalradian rocks. It is hoped that by describing in detail relatively small rock exposures this will assist geologists who have either little experience of structural geology or are unfamiliar with the area or the structural features found there, to identify the structures shown in cartoon form in (Figure 13.3). The excursion also illustrates the nature of the field evidence which can be used to analyse the sequence and geometry of structures in polyphase-deformed rocks. It is therefore essential that these exposures be preserved in their present state as there is little to be gained from hammering these low-grade rocks .

Please do not take hammers on this excursion

Itinerary

Travelling from Glasgow, coaches should proceed direct to Rosneath via Garelochhead using the A814 and B833. Note that Rhu Point, the prominent spit which extends into the Gare Loch 3 km (1.9 miles) NW of Helensburgh (Figure 13.1) marks the position of an important terminal moraine which is of the same age as that mentioned below. Mini-bus and car

drivers can follow a more scenic route along Glen Fruin: they should follow the A82 to Loch Lomond, take the B831 at the Arden roundabout to Crosskeys, and thence the single track road along the glen (Figure 13.1). 1.8 km (11 miles) NW of Crosskeys there is a large parking area [NS 323 857] opposite the end of the track to Inverlauren, which provides an excellent view of the Loch Lomond Readvance end-moraine. This moraine was deposited c. 10, 000 years ago and consists of a sand and gravel ridge with parallel meltwater channel (see Rose 1980 for further details). Ben Bowie with its cap of Lower Carboniferous lavas can be seen to the SE. The same end-moraine is crossed again at the head of the glen before the road descends in a series of hairpin bends (1:6 or 17% gradient) to join the A814.

Locality 1. Camsail Bay, Rosneath [NS 262 822]

Downward facing D_1 folds in a structural situation analogous to that of the hinge zone of the Aberfoyle Anticline (Tay Nappe). (Figure 13.1) (Figure 13.4)b

The first locality is 1.2 km (3/4 mile) SE of Rosneath church. Travelling south from Rosneath on the B833, take a left-hand turn in 1 km (0.6 miles), keep left at fork in minor road and after 200 m park in the lay-by at the bend in the road. From the lay-by, walk back up the road for 40 m for easy access to the beach, then skirt around the seaweed-covered exposures of steeply dipping greywackes and slates on the SE side of the small bay (Camsail Bay), and clamber up on to the promontory. Note in passing the smooth glaciated surfaces on some of these exposures. The surfaces dip moderately NW and show sharply incised glacial scratches and grooves trending NW–SE; the manner in which the rock has been plucked away along the SE edge of some surfaces indicates ice flow towards the SE. The rockhead was once covered by boulder clay and this is sometimes exposed in the steep bank by the refuse tip.

The rock exposure on the small promontory illustrates well the importance of choosing the most appropriate direction for viewing, and hence interpreting, structures in the field. Looked at from above, it presents a rather featureless glaciated rock surface crossed in places by cm-spaced, irregular, anastomosing stripes which are the end-on view of a near vertical spaced cleavage. However, if you make your way down the steep front face of the exposure and, tide permitting, stand on the shingle and look back southwest towards the rock face, you can see the structures sketched in (Figure 13.4)a. The low cliff represents a profile section through a series of gently plunging, upright folds.

The rocks belong to the Bullrock Greywacke ((Figure 13.4)b; (Table 13.1)) and consist of thick beds (>1 in) of feldspathic greywacke with thin intervening layers of siltstone and slate. Many of the rocks are coarse-grained sandstones with clasts a mm or two in diameter: such rocks are informally referred to in the Dalradian literature as 'grits' or 'gritty sandstones' although they were probably deposited as turbidites. Some contain pebbles (to 0.5 cm) and show inverted graded bedding (Figure 4a). Some of the quartz grains are of the pale blue opalescent type characteristic of Dalradian rocks in Scotland and occur together with less common clasts of pink feldspar and some pinkish-orange quartz grains, typically found in sandstones of the Southern Highland Group. Excellent inverted cross-bedding is found in laminated siltstones at the far SE end of the exposure at the top of the beach ((Figure 13.4)a).

Bedding planes in these rocks are marked by narrow zones of gnarled-looking rock with irregular pits and sets of grooves where a more calcareous horizon a few cm thick has become carious by differential weathering. The thick greywacke units contain occasional isolated rounded or elongate areas which weather differently from the enclosing rock and in which bedding laminations are commonly preserved as a series of fine ridges or ribs. These calcareous concretions formed during diagenesis and because of their quartz -poor composition did not readily develop a spaced cleavage. The concretion at location a (Figure 13.4) has developed oblique to bedding. Near-vertical joint planes trending NW-SE cut across the bedding: master joints with this trend form the large surfaces on which the fold structures are displayed, and control the shape of the small headland.

A series of open to close, upright, downward facing D_1 folds are seen in the section ((Figure 13.4)a; most of them plunge gently SW towards 210–225° but locally they have slightly curved hinges and plunge NE. A spaced cleavage, consisting of cm-scale alternating quartz-rich and mica+chlorite-rich microlithons, which has formed as a result of pressure-solution processes, occurs in most of the greywackes. The cleavage is axial planar to the folds ((Figure 13.4)c, although slightly fanned in places, and dips vary between 77° to the NW, and vertical. In places there are traces of an embryonic second cleavage which is oblique to the spaced cleavage and dips at 70–80° SE. Clasts are locally flattened in the plane of the

cleavage. Slaty cleavage occurs in mudrocks now seen as grey laminated slates; an isolated calcareous concretion or nodule at the SE end of the section ((Figure 13.4)a is flattened parallel to the cleavage trace and, assuming that it had an initially near-spherical form, its present shape gives an approximate measure of the strain in the XZ plane. A bedding-cleavage intersection lineation, which is parallel to the hinges of the D_1 folds (see (Figure 13.4)c for a schematic representation of these structures), is locally seen on cleavage surfaces in mudrocks as a colour banding. Localities marked 'X' on (Figure 13.4)a show good examples of this feature; that at the SE end of the exposure is of particular interest as the interrelationships between bedding, cleavage, inverted cross-bedding and the intersection lineation can be seen clearly. The spaced cleavage is deformed by small kink bands in a few places ((Figure 13.4)a: their overall geometry is summarised in (Figure 13.4)d. They apparently result from sub-vertical compression (?gravitational loading) late in the Caledonian history of the area.

Several faults marked by small gullies can be seen to displace the bedding: they strike $207\text{--}225^\circ$ and dip steeply to either the NW or SE. Minor quartz-carbonate \pm chlorite veins (carbonate: yellowish colour, often weathered out; chlorite: grey-green to dull green, powdery appearance) trending oblique to bedding are seen; some are parallel to the spaced cleavage but none are deformed or lineated. The significance of the last observation will be seen later on.

The rocks making up the rock platform on the SE side of the small bay past the hut (off the left hand side of (Figure 13.4)a are greywackes with a strongly developed D_1 spaced cleavage. If you walk out on the nearest exposure to the beach just past the edge of the seaweed and turn to face the shore, two flat-lying blocks of greywacke up to 1 m long are seen within the regularly-cleaved rock. Both preserve gently dipping bedding surfaces and resemble the calcareous concretions described above. They are slightly folded by D_1 folds and show evidence of cleavage oblique to that in the adjoining rock. The manner in which they terminate along strike is also problematical, but one of them is cut and displaced by small fractures associated with kink bands and they may be fault-bounded. Farther SE along this section is a small quarry formerly used to provide building stone. The outcrop of the Dalradian rocks then ceases and the wide muddy bay to the SE of it marks the position of the northern branch of the Highland Boundary Fault ((Figure 13.4)b.

Across the bay ((Figure 13.4)b) is a short section exposing Upper Old Red Sandstone conglomerates and sandstones which strike N–S and dip at $40\text{--}50^\circ$ to the west. The conglomerates contain pebbles and cobbles up to 40 cm across, mainly of vein quartz, basalt, andesite, granite, porphyry and greenschist. Some of the clasts of metamorphic rock have a spaced cleavage and resemble the local Dalradian rocks. The Upper ORS rocks of the Rosneath Peninsula were described by Bluck (1980), who concluded that they were deposited in an alluvial fan environment. At the SE end of the exposure a 30 cm-thick sandstone-conglomerate unit is offset by three faults which trend between $230\text{--}260^\circ$ and dip to the north, and a large fault with a cemented fault breccia, which trends at 113° .

Retrace your route across the bay and exit from the coast along a small path which passes between the Navigation Beacon and the large fenced compound. This leads to a road; turn right, then left at the next junction to regain the lay-by after 200 m. Please note that the track leading to the hut is private and must not be used. Although it is nearby, locality 1 of Roberts (1977) (Figure 13.4)b, R1 is not recommended: it is a disused, partially flooded quarry with dangerous rock faces emblazoned with graffiti.

Locality 2. Barons Point, Kilcreggan [NS 223 808]

Medium-sized D_2 fold with axial-planar spaced cleavage (Figure 1) & (Figure 4)b.

From the lay-by return to the B833 and turn left for Kilcreggan. The road traces the margin of the Dalradian outcrop, with the Highland Boundary Fault occupying the broad hollow to the south of it.

If you are interested in the Upper Old Red Sandstone, Roberts (1977) locality 2 is worth a visit. Take a sharp left hand turn at the bottom of the hill into Kilcreggan, keep left along the single track road, and where it divides drive between the stone gateposts to park inside the King George V Recreation Ground. [Note: This area has been offered for development, so access to the section may change in future.] The Upper ORS conglomerates and sandstones are exposed in an old sea cliff: the beds dip $20\text{--}30^\circ$ NW and are cut by steep SE-dipping extensional (normal) faults. The section demonstrates the variation in size and composition of the clasts in the ORS conglomerate (see Bluck 1980 for

further details and regional setting).

After leaving Kilcreggan, pass the Tut-Tut (two painted glacial erratics on the foreshore) after 1 km (0.6 mile), and 1 km farther on park in a large car park on the right hand side of the road by Cove Burgh Hall and Craigrownie Parish Church. From the car park walk 140 m north beside the A833 and when opposite the house named Kirklea take the small path to the beach. Bear left for 15 m along the beach and examine the coarse-grained greywacke exposed in the small cliff face. The rock is made up of closely spaced, rather discontinuous layers—are these of sedimentary or tectonic origin? If tectonic, are they of D_1 or later age? The answer to this puzzle can be found a few metres farther south along the beach by climbing a little way up on to the sloping rock face and looking down towards the south. The clear relationship between these closely-spaced surfaces, and bedding planes marked by the margins of thick greywacke units, can be seen (Figure 13.5).

The bedding planes define an antiform, with a measured inter-limb angle of 50° , which has a well-developed, slightly fanned axial-planar spaced cleavage. The cleavage dips at $34\text{--}36^\circ$ towards the SE and SSE. The hinge of the fold, which plunges at 40° due south, is well exposed and at several places around the structure the bedding-cleavage intersection lineation is seen (L on (Figure 13.5)), both as a bedding intersection on the cleavage and as cleavage stripes on the bedding. These lineations vary slightly in plunge, but all fall within 13° of the orientation of the exposed hinge line. A possible stretching lineation is found on the cleavage surface at location S (Figure 13.5) and sets of late kink bands are found on each limb of the fold.

Thin quartz veins, some of which are lineated, are either approximately parallel to the spaced cleavage or are more steeply dipping and oblique to it. A quartz-carbonate vein up to 9 cm thick cuts the fold and bifurcates to the west. It contains abundant euhedral pyrite and has a 'bleached' alteration zone up to 1.5 cm wide on either side of it.

Evidence that the spaced cleavage is of D_2 age has been found in thin-section but can also be seen in the field at nearby exposures. Return to the path onto the beach and closely examine the spaced cleavage by looking ENE along strike at clean, vertical rock faces. Traces of the D_1 spaced cleavage can be seen within the D_2 microlithons and this is particularly clear in the last exposure SE of the path as you leave the beach (Figure 13.5)b. This feature will be examined in more detail at Locality 5.

The rocks at Locality 2 have been previously included with the outcrop of the Dunoon Phyllite (Roberts 1977, fig 2) but are greywackes which possibly have more Ethological affinity with the younger Bullrock Greywacke (Table 13.1), although lacking the detrital pink feldspars which characterize the latter. Rock types typical of the Dunoon Phyllite are seen at the next locality.

Locality 3. Barons Point, Kilcreggan [NS 222 809]

Disharmonic, curvilinear late folds ($?D_4$) and crenulation cleavage in the Dunoon Phyllite. (Figure 13.1) & (Figure 13.4)b.

The locality is out of geological sequence in that features such as the D_2 stretching lineation are better studied at Locality 4, where they are unaffected by later folding. However, this is impractical.

From Kirklea (Locality 2) walk 110 m north along the pavement to the start of a wall made from alternating panels of stonework and iron railings, cross the road, take the path on the right into the small recreation area. Here, turn left down a path on to the beach after 35 m. The area of interest lies between the iron pipe and the low cliff to the south of it.

The rocks are black phyllites (originally mudstones and siltstones) with quartz veins, and buff brown lenses and bands of limestone to 40 cm thick, all belonging to the Dunoon Phyllite. The fold structures in these rocks are best viewed from the rock platform looking east towards the shore (Figure 13.6). They consist of a series of asymmetrical warps with wavelengths of a few cm to 0.5 m which verge northwards and fold a prominent lineation. The folds are disharmonic and when viewed from above are seen to have quite strongly curved hinges which cannot be traced for a long distance; these features are best seen in the rocks around a grass-topped knoll just south of where the path reaches the HT mark, and on a large exposure near the low-tide mark.

The asymmetrical folds in the phyllites deform a penetrative, slaty-looking cleavage which from thin-section examination is concluded to be of D_2 age. Later structured fabrics such as these are typically more strongly developed in the finer-grained rocks than they are in the more competent grits and greywackes. Some quartz-carbonate veins are folded and boudinaged, probably during the same event which gave rise to the cleavage, and these contain a quartz fibre lineation which is parallel to the down-dip stretching lineation seen on the cleavage surfaces. These lineations are also folded by the late asymmetrical folds which show the same style, vergence and geometry as D_4 minor folds seen farther north in the vicinity of the Downbend Antiform. The folds result from localized D_4 strain in an incompetent, fissile unit SE of the general zone in which the D_4 deformation typically affects all lithologies (Figure 13.3).

A new crenulation cleavage is developed parallel to the axial surfaces of the late folds. Both discrete (marked by small fractures) and zonal (marked by microcrenulations) types of cleavage are present, and a crenulation lineation is seen parallel to the fold hinges.

Return to the car park either by retracing your route along the B833, or if the tide is sufficiently low, by an easy walk along the coast to the Memorial cross opposite the car park.

Locality 4. Knockderry Castle [NS 215 834]

D_2 minor folds with northerly vergence associated with a new D_2 fabric and a stretching lineation.

From the car park travel north on the B833 through Cove for 3 km (1.9 miles) to Knockderry Castle. Beware of meeting coaches at the very sharp right-hand bend just before the Castle. Park in the lay-by (large enough to take a coach) which is on the left-hand side of the road just after the road straightens out following the double bend.

The whole section adjacent to the lay-by shows features of interest but it is best to start in the short stretch at the north end of the section before examining the remainder. The rocks here are greywackes and phyllites belonging to the Beinn Bheula Schists.

Walk northwards along the road for 65 m and take the small path left to the shingle beach. Northwards from here there are numerous examples of minor folds with a Z-profile (northward vergence); they plunge at about 35° to the SSE (204°) and have axial planes which dip at $45\text{--}50^\circ$ to the SE. Careful examination of the hinge zones of these minor folds shows that they fold both the lithological layering and an early spaced cleavage (D_1). A new, generally widely-spaced, pressure solution cleavage is developed parallel to the axial surfaces of the folds and where the two cleavages are locally of equal development (especially in the more siliceous rocks) the layers are divided up into columns with a rhombic cross-section. These features are illustrated in a composite sketch in (Figure 13.7)a.

After about 40 m there is a small overhanging face with an iron pipe to the north of it. On the low rock platform between the pipe and the wall at the end of the section is an exposure of grey-brown phyllite. Bedding in the phyllite is marked by rusty-coloured bands which make a high angle with the cleavage and give rise to a very clear bedding-cleavage intersection lineation. Although the cleavage looks like a first generation penetrative slaty cleavage in the field, under the microscope it is seen to be a very closely spaced D_2 crenulation cleavage with much new growth of white mica parallel to the D_2 cleavage surfaces. The same features are seen at the southern end of the section where the main fabric in a thick band of phyllite is a micro-scale (D_2) crenulation cleavage axial planar to folds revealed by colour banding in the rock. In the phyllite at the north end of the section, a fine D_2 stretching lineation plunging at 48° to 137° is seen on the cleavage planes and, in good light, a very fine near-horizontal crenulation lineation can be seen on some of these surfaces, in addition to variably-orientated kink bands. These features of the phyllite are summarised in (Figure 13.7)b.

It is an instructive exercise to measure the orientation of the axial surfaces and hinges of folds in the greywackes, and the orientation of the cleavage surfaces and bedding-cleavage intersection lineations in the phyllites and compare them. It should be clear that, if sufficient measurements are made, the axial surfaces of the folds and of the cleavages are statistically parallel, as are the hinges of the folds and the bedding-cleavage intersection lineations. The geometry and vergence of these D_2 structures is particularly well shown in a good three-dimensional exposure of a Z-fold at a point on the rock platform exactly in line with the wall at the end of the section. As we move northwards into the Flat Belt such D_2

folds become difficult to identify as the pressure-solution cleavage becomes dominant and strongly overprints and obscures the bedding.

Deformed quartz veins are found in both rock types and many of them carry a fairly coarse quartz fibre lineation which represents the direction of extension during D_2 and is parallel to the stretching lineation seen in the phyllite ((Figure 13.7)c). Later quartz veins oblique to the D_2 cleavage are also seen, and two thick siliceous greywacke beds (up to 0.6 m thick) near the iron pipe have behaved as particularly competent units and show several sets of extensional quartz veins.

Other features to note on the return journey along the rock platform to the lay-by are:—a) intersection lineations between the D_1 and D_2 cleavages on the sides of upstanding D_2 microlithons, b) a few brown-weathering limestone bands, and c) centimetre-scale graded sandstone units which if thin-sectioned give clear evidence that the beds are inverted and that the D_2 folds face down to the south.

Locality 5. Letter Layo, Coulport [NS 212 869]

Modification of bedding and D_1 cleavage during formation of D_2 microlithons (Figure 13.1)

From Locality 4 continue north for 3.5 km (2.2 miles), past the turning to Garelochhead, and park at the northern end of the second long lay-by, opposite the track to Letter Layo. This locality is valuable in showing different stages in development of the D_2 microlithons which, in the more deformed rocks farther north, provide a datum for identifying the D_3 and D_4 structures. Superb examples of these structures were once exposed on the coast just past the Royal Naval Armaments Depot at Coulport but these have now been destroyed as a result of the Trident expansion programme.

The best examples of D_2 microlithon development are seen at the extreme north end of the section. This is reached either by walking north along the road (beware traffic on bend) and turning on to the beach after 100 m, or walking along the coast and around the small headland. The 75 m of wave-washed exposures north of the iron pipe are best, and at the far north end clear relationships between bedding (marked by brown unclesaved or poorly cleaved greywackes), the D_1 cleavage (clockwise to bedding at various angles), and the D_2 cleavage and microlithons (anti-clockwise to both bedding and D_1 cleavage) are seen. These relationships are shown schematically in (Figure 13.8). Grading shows the beds to be inverted at the north end of the section and both the D_1 and D_2 folds are downward facing (Figure 13.8). There are numerous deformed quartz-carbonate-chlorite veins in these rocks.

In places the mean orientation of the deformed D_1 fabric is at right angles to the trace of the D_2 cleavage: a relationship commonly seen in the former exposures at Coulport. The D_2 hinges and the intersection lineation between the D_1 cleavage stripes and the D_2 microlithons plunges at 38–520 to 176–206°, similar to their orientation at Locality 4. The green phyllite bands have a penetrative D_2 micro-scale crenulation cleavage, similar to that of the brown phyllite at Locality 4, which is axial planar to folds defined by lithological banding plus D_1 cleavage. D_2 microlithons appear pale in some rocks due to their probable enhanced quartz content.

Similar relationships to those described above are found in the rest of the section and are best viewed by looking down-dip at the rocks on the return journey to the lay-by. Near the iron pipe, glacial scratches and grooves on WNW–dipping ice-smoothed surfaces trend 333° and plucking structures indicate ice flow to the SSE.

Locality 6. Portincaple, south section [NS 228 932]

Steep south limb of the Downbend Antiform adjacent to the hinge zone; development of D_3 and D_4 minor folds and fabrics (Figure 13.1) & (Figure 13.9).

From Letter Layo drive a short distance north to the Coulport roundabout, take the MOD road to the Whistlefield roundabout (Figure 13.1) where you take the first exit (A814, Arrochar) and 200 m after passing under a railway bridge, make a sharp left turn to Portincaple (signposted). Limited roadside parking is available in the village for cars and mini-buses (see (Figure 13.9)); coaches should drop the party at the road junction and return to pick them up at an appointed time. Allow at least 2 hours for the stop at Portincaple (Localities 6 & 7).

The rocks at Localities 6 and 7 are greywackes with thin phyllite horizons belonging to the Beinn Bheula Schists. No clear and entirely unambiguous way-up structures have been noted in these rocks, which is not surprising since they have been affected by two episodes of penetrative deformation and pressure-solution (D_1 & D_2), and two further episodes of folding (D_3 & D_4). Three roughly N–S trending dykes labelled here Da-c occur at Portincaple. All are pale brown in thin section, consisting largely of an interlocking mosaic of cloudy feldspar laths (to 0.3 mm long) and some quartz, and are highly altered with much calcite and chlorite. They can probably be correlated with the felsic dykes of the Lower Devonian age shown in the adjoining area of BGS Sheet 38W (Loch Lomond). The thick dyke D^d (Figure 13.9) is less altered and is a continuation of the Permo-Carboniferous quartz-dolerite (Q^d) that has been traced ENE to just south of Inverbeg Hotel on sheet 38W.

Please do not hammer the Dalradian rocks at Portincaple.

The route to the beach is shown on (Figure 13.9): near the end of the main track turn left across the bridge over the stream, take the path through an iron gate, past the boatyard. Follow the path through a second iron gate, keeping to the left hand path (muddy) which leads down to a small bay with a large grass-covered knob of rock on the north side. Asymmetrical gently plunging D_4 folds can be seen on the south side of the knoll, and are best viewed downplunge to the ENE (065°). The folds are reminiscent of those seen at Locality 3 (Figure 13.6) but here occur in more siliceous greywackes. Section AB (Figure 13.10) starts at the gully on the north side of this exposure. Deep water lies close to the edge of the rock platform at all states of the tide and the rocks are slippery—take care!

Section AB (Figure 13.10) lies on the south limb of the Downbend, a regional monoform whose axial trace passes approximately between Localities 6 and 7. The axis is poorly defined because the structure has a complex rounded hinge zone. The section is dominated by a steep southerly dipping composite foliation which comprises bedding modified by the D_1 and D_2 cleavages and is now largely seen as a strongly developed D_2 fabric. As shown in cartoon form in (Figure 13.3) (between Localities 5 & 7) this foliation is locally affected by minor D_3 folds which have a southerly vergence (Z-shaped down-plunge profile). A new D_3 spaced or crenulation cleavage is developed in places, although this is seen best farther north in more pelitic units. Superimposed on all of the earlier folds and fabrics are abundant, gently plunging, D_4 minor folds which verge north towards the antiform ((Figure 13.3), Locality 6) and are locally accompanied by yet another crenulation or spaced cleavage. As deformation increases northwards across the area, where bedding can be seen it generally parallels the D_2 fabric.

The section is dissected by ten faults, several of which occupy gullies and give rise to pronounced steps in the rock platform (Figure 13.10). They dip at $44\text{--}84^\circ$ S and strike consistently at $070\text{--}075^\circ$ broadly parallel to the mean trend of the main foliation. In detail, however, beds are cut out at the fault planes, especially in the footwall.

Dyke D^a is poorly exposed: it trends 343° and occupies the gully at the beginning of the section AB (Figure 13.10). In the first 10 m of the section a planar D_2 fabric (identification checked in thin section) dipping at about 60° S dominates the exposure, and by careful searching, D_2 microlithons can be found (Figure 13.10). Thus the structural situation is approximately equivalent to that at Letter Layo (Locality 5) except that here the D_2 fabric is more intensely and uniformly developed and it is also affected by later folds and warps. The D_1 'stripes' in more siliceous beds are with few exceptions preserved as relics within D_2 microlithons. Farther along the section most of the folds are of D_4 age and have a northerly vergence (with one steep and one gently dipping limb) and steep NNW-dipping axial surfaces. A typical, rather widely-spaced, D_4 crenulation cleavage is developed locally in the more argillaceous rocks, as at location a (Figure 13.10), and D_2 microlithons are folded.

To maintain the same profile view of the and D_4 structures, a new line of section has to be taken when the two glacial erratics are reached. Fault b (Figure 13.10) is traced eastwards across the rock platform to its inferred position in a grassy knoll at b'. At location c (Figure 13.10), on a low cliff face formed parallel to a N–S fault, small symmetrical D_4 folds occur on the gently dipping middle limb of a much larger D_4 fold. A steeply dipping D_4 cleavage is developed locally and regularly-spaced D_2 microlithons are folded around the structures. On the rock platform in front of these structures, curvilinear ($?D_4$) folds seen in three dimensions deform a clear D_2 stretching lineation which trends NW-SE and is parallel to a quartz fibre lineation seen in nearby deformed quartz veins (cf. Locality 4, (Figure 13.7)b).

The line of section changes again at the next fault, which occupies a pronounced gully and in its footwall at location d (Figure 13.10) are a set of well-exposed curvilinear E- and W-plunging D_3 folds which fold the D_2 fabric. They have axial surfaces dipping at $<20^\circ$ N which are parallel to a D_3 crenulation cleavage and are in marked contrast to the generally more steeply dipping D_4 structures. At a lower level in the footwall section, and also affecting the D_3 folds, is a train of symmetrical, open, doubly-plunging, upright D_4 minor folds which deform the D_2 stretching lineation and show hinge-parallel crenulation lineation trending ENE–WSW.

Having reached the end of the section at B walk along the rock platform to the jetty. Dyke D^b , which strikes N–S and is 1.5 m thick, crops out just south of the jetty. From here to section CD (Locality 7) the rock exposure is neither as good nor as continuous as in the other two areas but there are several small cliff faces which display relationships between the various sets of structures similar to those described above.

In the rock face on the north side of the track to the jetty is an example of D_2 microlithons being reworked to form D_3 microlithons. Dyke D^c forms a wall-like exposure 40 m farther north: it has an almost N–S strike, dips $50\text{--}56^\circ$ W, and is partially brecciated and highly carbonated. A prominent rock face some 50 m north of the dyke shows a 0.8 m-thick band of pebbly greywacke with prominent clasts (to 8 mm) of blue quartz and cloudy feldspar; there is a thin skin of fault breccia adhering to the face. This massive unclesaved rock contrasts with the thin greywacke sandstones, quartz veins and phyllites noted above, which contain D_4 folds with a discrete crenulation cleavage superimposed on D_3 folds. It shows that even in rocks as deformed as these are, competent units still appear to remain relatively undeformed and unaffected by pressure-solution processes. Another clean rock face is seen 15 m farther on and 5 m south of the southern margin of a quartz dolerite dyke, D^d . It occurs at the end of a small cliff near a group of large boulders and is the best example in this section of D_2 microlithons and early quartz veins folded by D_3 folds and overprinted by a steep to vertical D_4 crenulation cleavage in the phyllites. The dyke has a chilled margin, is of probable PermoCarboniferous age, and trends approximately east-west; it is ~ 18 m thick and both contacts with the Dalradian rocks can be examined.

Locality 7. Portincaple, north section [NS 231 934]

Hinge zone and north limb of the Downbend Antiform; large D_3 folds. (Figure 13.1) and (Figure 13.9).

From dyke D^d cross the beach and head NE for the landward end of the large groyne which marks the start of the section CD (Figure 13.9) & (Figure 13.10). This section lies slightly to the north of the main hinge zone of the Downbend Antiform (Figure 13.3). Features of interest are the thick-bedded, coarse grained greywacke units (grits) making up much of the sequence, part of the Beinn Bheula Schists, and the presence of several key bedding surfaces which can be traced right across the exposures and are marked by a dotted ornament on (Figure 13.10). The greywackes contain clasts up to 0.5 cm across and have a finely spaced (1–3 mm) pressure-solution cleavage which is discontinuous in appearance, resembling that seen earlier at Locality 2, and here folded by D_3 and D_4 folds. Large-southward verging D_3 folds and minor D_3 folds are overprinted by upright, symmetrical D_4 warps and small folds which have an axial-planar crenulation cleavage (Figure 13.3), Locality 7; and section CD, (Figure 13.10).

At location e (Figure 13.10) D_2 microlithons containing the D_1 fabric are affected by gently plunging (11° to 062°) D_4 warps with a near vertical crenulation cleavage striking at 060° . Nearby, at location f (Figure 13.10), is a rock face over a metre across which, when dry and seen in good light, shows the initially puzzling, set of structures shown in (Figure 13.11). A partial explanation for this complex pattern is that the lamination seen approximately parallel to bedding at X (and apparently anticlockwise to bedding on the lower face) is the D_1 spaced cleavage; the steeply dipping fabric reworking it is the D_2 spaced cleavage (Y); and the folds which deform the early spaced cleavage along the bottom edge of the surface are minor D_4 folds. The unit is a single bed of non-graded coarse-grained greywacke containing blue opalescent quartz pebbles to 5 cm across.

Locality 8. Glenmallon, Loch Long [NS 249 965]: Structures illustrating the geometry of the 'Flat Belt' (Figure 13.1).

From Locality 7 return to the main road (A814) and travel some 4 km (2.5 miles) to the dock at Glenmallon. After passing the entrance to the MOD private road to Glen Douglas on the right hand side, continue for a further 370 m and park in the large lay-by on the left. Prior permission has to be obtained from the MOD (at the nearby control post, if manned) to park

in the MOD car park on the Glen Douglas road.

The locations noted below are all in the greywackes and associated rocks of the Beinn Bheula Schists. These locations when taken together give on the one hand a good impression of the beguiling structural simplicity of the 'Flat Belt' and on the other hand give indications of the true complex structural state of the rocks i.e. that these rocks have undergone the same D_1 – D_4 structural events as rocks on the steep, south limb of the Downbend (see Locality 8, (Figure 13.3)) but with greater intensity. The structural age of spaced fabrics in the 'Flat Belt' is not easy to determine as D_1 stripes are sometimes preserved and may be reworked by D_2 , D_3 and even D_4 microlithons. Typically, D_2 cleavage dominates the exposures and related megascopic D_2 folds if present are difficult to discern. Rock exposures are accessible from two platforms constructed on Loch Long side and in a small cutting at the entrance to the turning to Glen Douglas.

From the lay-by, walk back south 160 m to the path and steps down to the first platform. The exposures here show a nearly horizontal D_2 fabric corrugated by D_4 minor folds, which plunge towards 055° and are accompanied by a strong crenulation lineation. A faint stretching lineation (? D_2) trending 133 – 143° is seen on some surfaces and flat-lying D_2 microlithons can be seen in the exposure by the foot of the lamp post. Return to the road, past the path to the second platform (no access to rocks) and continue south for a further 40 m to platform 3. Access is via a steep 4 m steel ladder and there is a good view of exceptionally planar (for these rocks), flat-lying beds to the south of the platform. D_2 microlithons deformed by D_4 folds are seen along the seaward edge of the exposure north of the platform. Having returned to the road then walk a farther 150 m south, cross the A814 to examine the rock face on the south side of the road to Glen Douglas. The part of the face closest to the main road shows evidence of all of the deformation phases. The overall near-horizontal foliation is folded by upright D_4 folds, which locally have a chevron style, and there are many thick, irregular, sub-horizontal quartz veins. Note that these veins are not deformed and lineated, and are later in age than the syn- or pre- D_2 veins noted farther south. D_3 minor folds verging south are common (good examples occur 4 m north of the 'parking area' sign near the north end of section) and deform a spaced cleavage that can be seen to be of D_2 age; they also fold D_2 isoclinal folds which themselves fold the D_1 spaced cleavage. The early stages of both D_3 and D_4 microlithon development are seen in these rocks as 1–2-cm wide bands of folded or kinked D_2 fabric.

There are three possibilities for the return journey to Glasgow:

a. Retrace the route via the A814 through Helensburgh; b. Continue north along the A814 past the old Murlaggan landslip to Arrochar, then turn east to Tarbet and examine some of the localities along the A82 Loch Lomond section (Excursion 11); or c. if travelling in a car or mini-bus continue north for 5 km (3 miles) on the A814 and take the single track road (some hairpin bends and steep gradients) through Glen Douglas to join the A82 at Inverbeg. Note the landslip on Tullich Hill immediately to the north on entering Glen Douglas from this direction.

Acknowledgements

I am grateful to John Mendum for reviewing, and suggesting valuable improvements to this article: to Bill Henderson for his comments on the geology of the Coulpport–Kilcreggan area; and to Alec Herriot for advice on the igneous dykes.

References

- BLUCK, B.J. 1980. Evolution of a strike-slip fault-controlled basin, Upper Old Red Sandstone, Scotland. *Spec. Publ. Mt. Ass. Sediment.* 4, 63–78.
- BRADBURY, H.J., HARRIS, A.L. and SMITH, R.A. 1979. Geometry and emplacement of nappes in the Central Scottish Highlands. In Harris, A.L., Holland, C.H. & Leake, B.J. (eds), *The Caledonides of the British Isles-Reviewed*. *Spec. Publ. Geol. Soc. London* 8, 213–20.
- HARRIS, A.L., BRADBURY, H.J. and MCGONIGAL, M.H. 1976 The evolution and transport of the Tay Nappe. *Scott. J. Geol.* 12. 103–13.

- HARTE, B., BOOTH, J.E., DEMPSTER, T.J., FETTES, D.J., MENDUM, J.R. and WATTS, D. 1984. Aspects of the post-depositional evolution of Dalradian and Highland Border Complex rocks in the Southern Highlands of Scotland. *Trans R. Soc. Edinb.: Earth Sci.* 75, 151–163.
- MENDUM, J.R. and HUES, D.J. 1985. The Tay nappe and associated folding in the Ben Ledi-Loch Lomond area. *Scott. J. Geol.* 21, 41–56.
- ROBERTS, J.L. 1977. The Dalradian rocks of Rosneath and south-east Cowal. *Scott. J. Geol.* 13, 101–11.
- ROGERS, G., DEMPSTER, T.J., BLUCK, B.J. and TANNER, P.W.G. 1989. A high precision U-Pb age for the Ben Vuirich granite: implications for the evolution of the Scottish Dalradian Supergroup. *J. Geol. Soc. London* 146, 789–98.
- ROSE, J. 1980. 'Rhu' and 'The western side of Loch Lomond' In: Jardine, W.G. (ed.) *Quaternary Research Association Field Guide: Glasgow region.* 31–39.
- SHACKLETON, R.M. 1958. Downward-facing structures of the Highland Border. *Q.J. Geol. Soc. London* 113, 361–92.

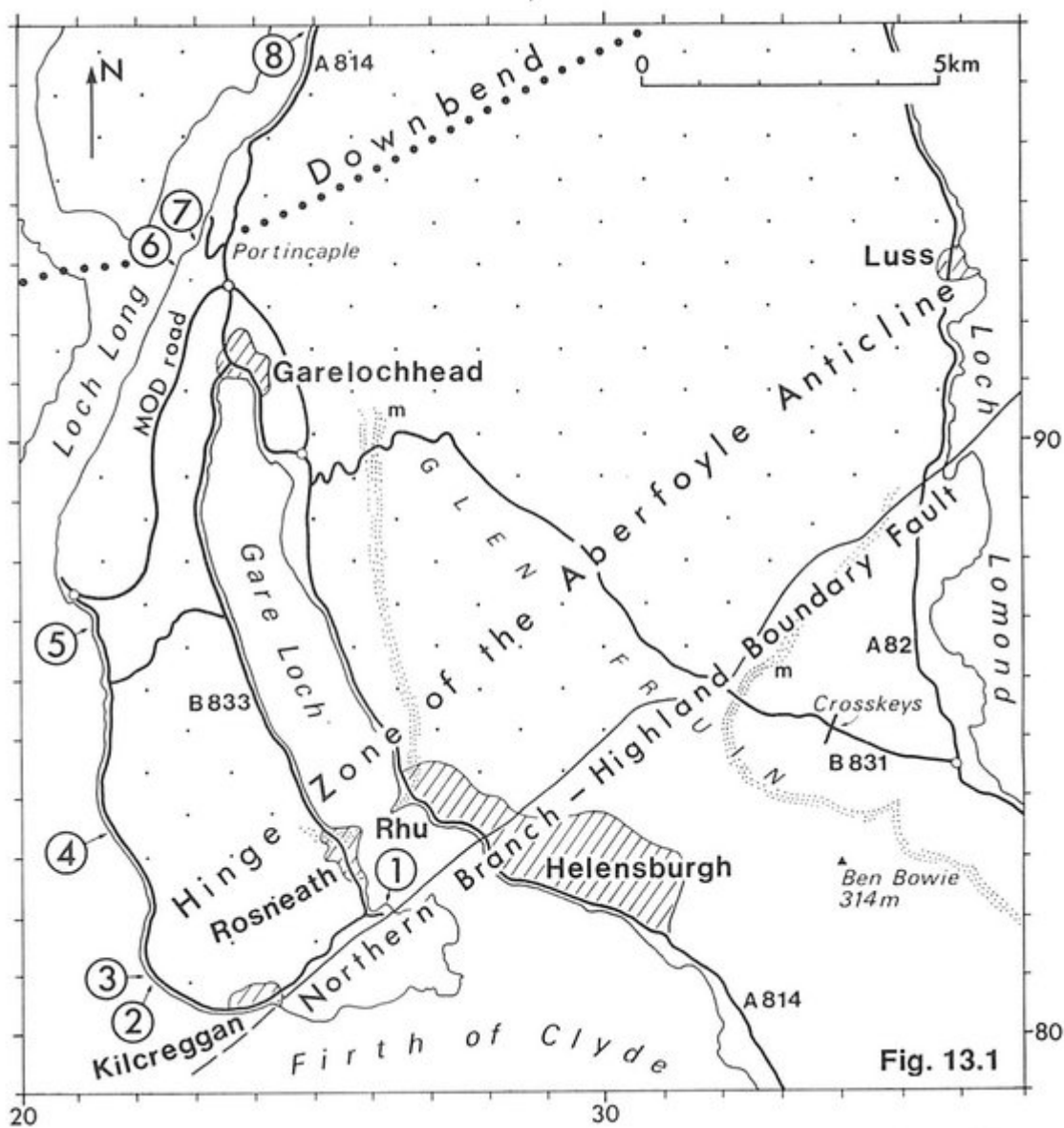

(Figure 13.1) Regional setting of the Localities 1–8 described in this guide. Dalradian rocks are shown by a dotted ornament. m, Loch Lomond Readvance terminal moraine.

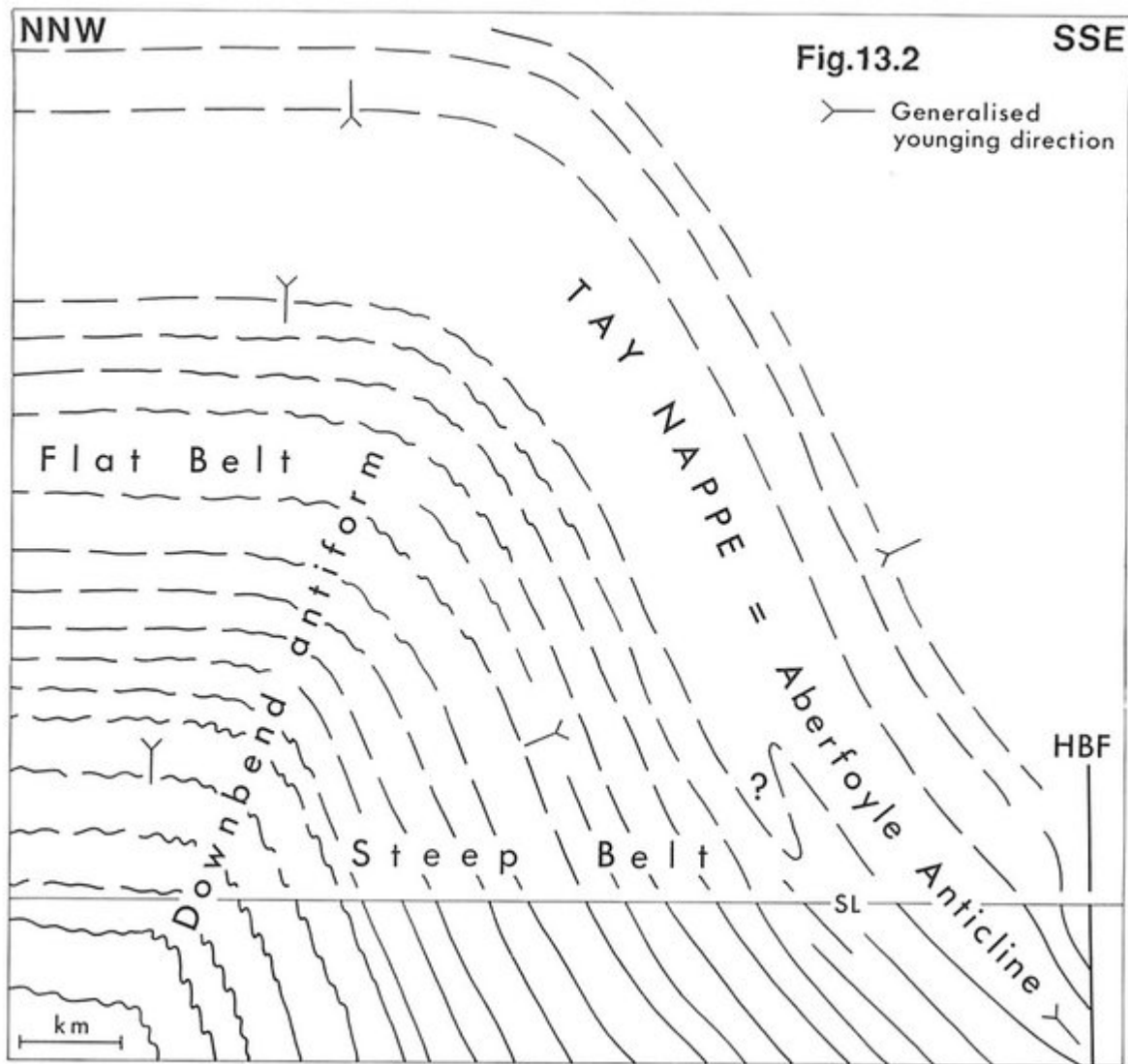

(Figure 13.2) Schematic cross-section parallel to the Gare Loch (Figure 13.1) showing the main structural elements in the area. HBF, Highland Boundary Fault.

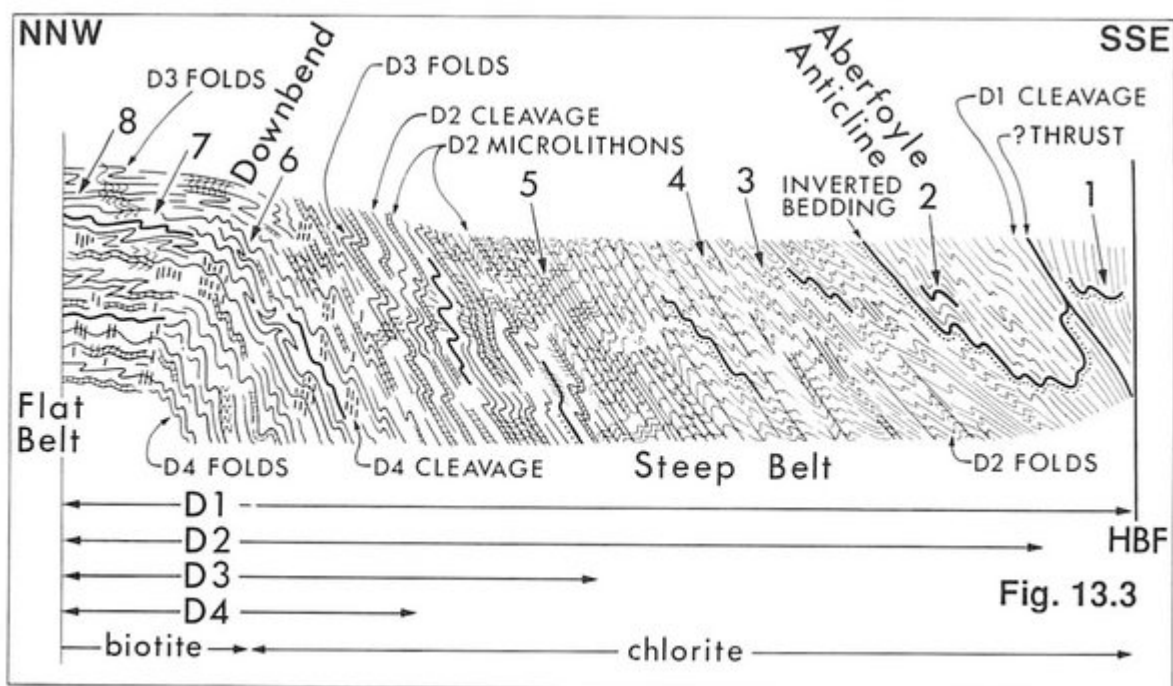

(Figure 13.3) Vertical section showing in cartoon form the style, orientation and sequence of deformations along the section shown in (Figure 13.2) Numbers 1–8 refer to the Localities described in this guide.

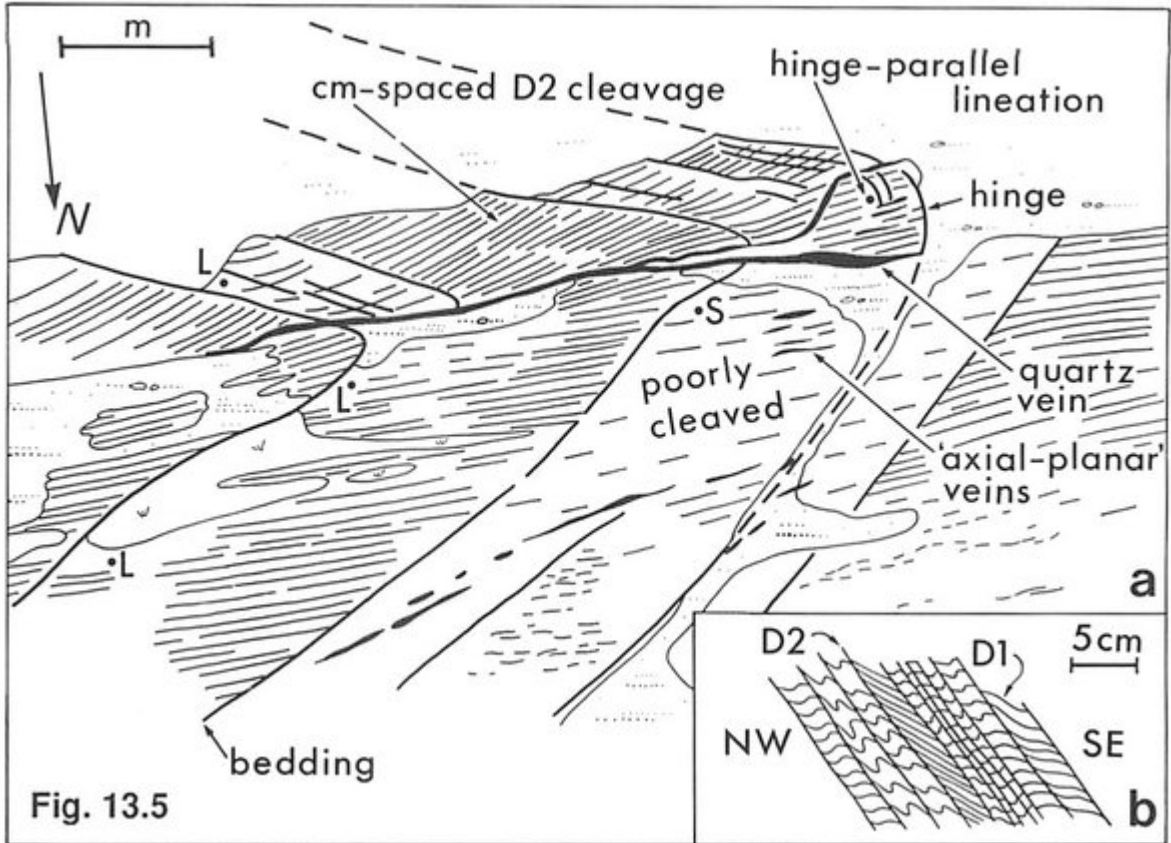

(Figure 13.5) a) Down-plunge true-scaled drawing of a D_2 fold at Locality 2. L, location of bedding-cleavage intersection line; S, possible stretching lineation. b) Close-up view of the D_2 cleavage showing the deformed D_1 cleavage.

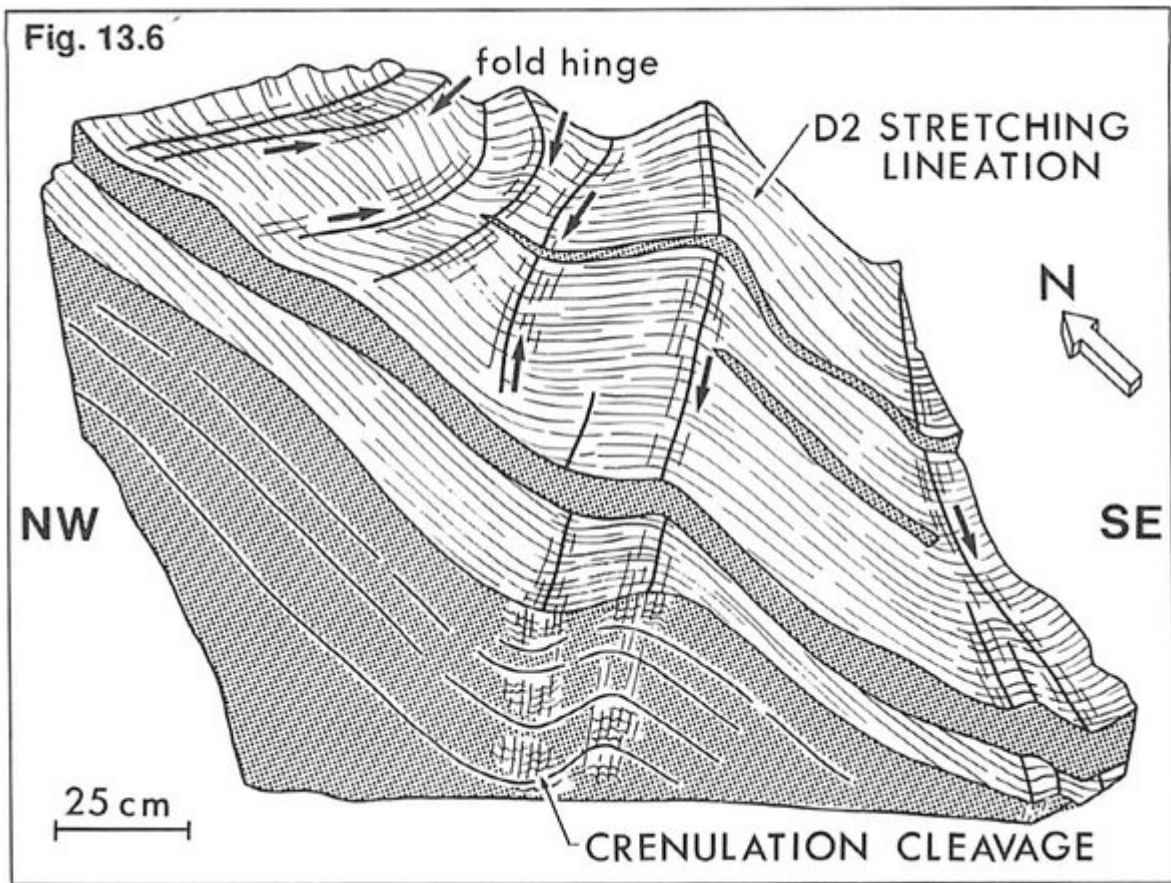

(Figure 13.6) Sketch showing the salient features of the disharmonic, curvilinear late folds ($?D_4$) at Locality 3. Arrows indicate the approximate direction of plunge of the fold hinges.

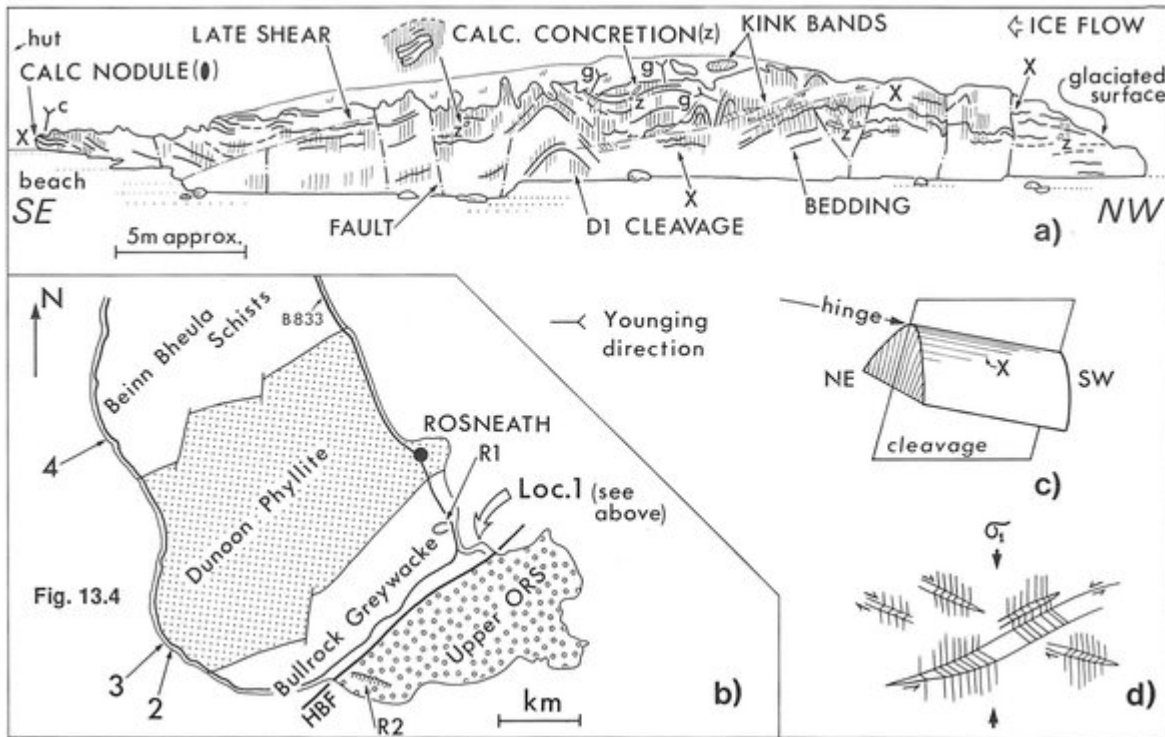

(Figure 13.4) a) True-scale drawing of geological features seen at Locality 1 on the headland in Camsail Bay, viewed from the NE. Younging directions are shown by a short arrow: c, cross-bedding; g, graded bedding. x, locality where bedding-cleavage intersection lineation can be seen. b) Locality and outline stratigraphical map of the area around Rosneath. R1 & 2 are localities from Roberts (1977) c) three-dimensional sketch of an idealised fold. d) Geometry of kink bands at Locality 1. σ_1 maximum principal compressive stress. HBF, Highland Boundary Fault.

Southern Highland Group	
south of the Aberfoyle Anticline	north of the Aberfoyle Anticline
Bullrock Greywacke Dunoon Phyllite	Beinn Bheula Schists ? Dunoon Phyllite

(Table 13.1) Stratigraphy of the Dalradian rocks of the Rosneath–Loch Long area Southern Highland Group south of the Aberfoyle Anticline north of the Aberfoyle Anticline Bullrock Greywacke Dunoon Phyllite Beinn Bheula Schists Dunoon Phyllite

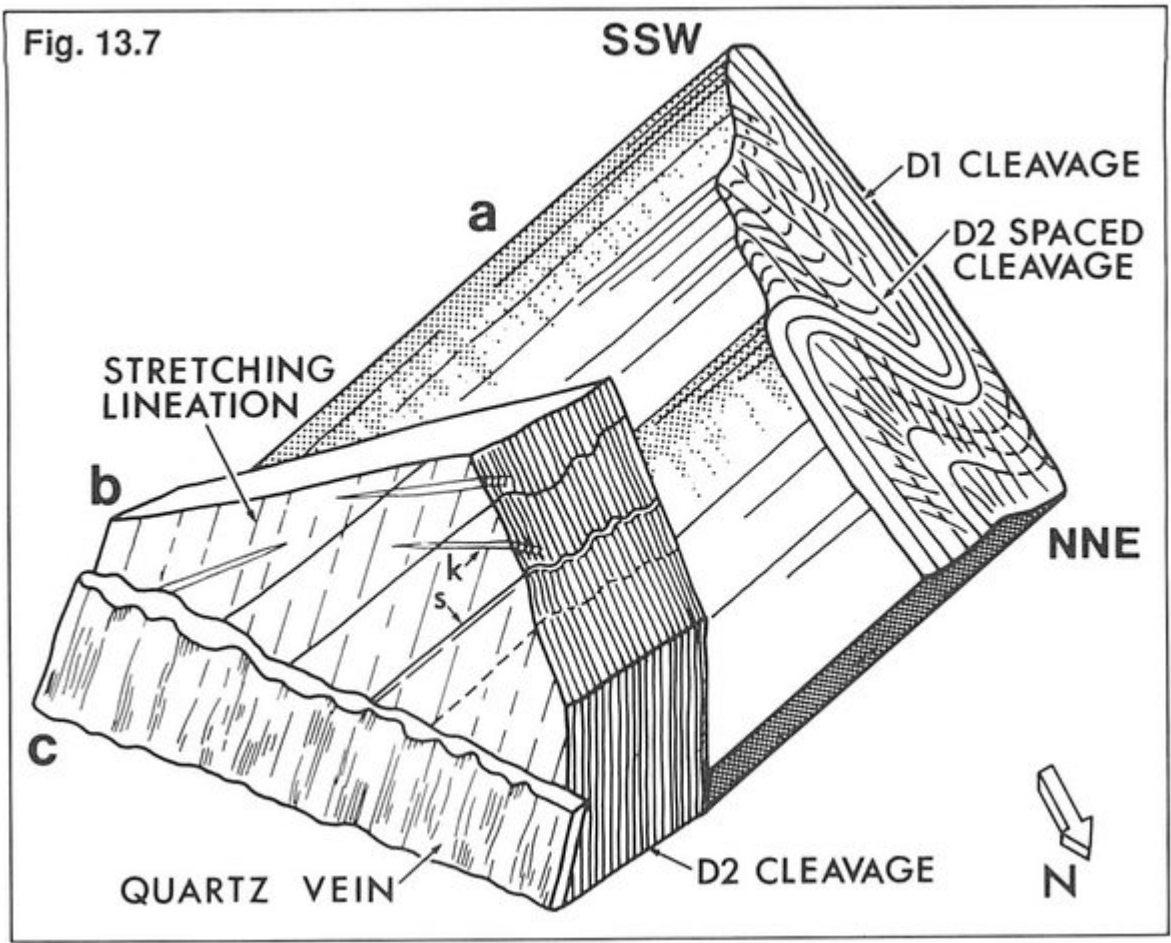

(Figure 13.7) Composite diagram showing the geometrical relationships between:- a) D_2 folds; b) D_2 penetrative cleavage in phyllite, and c) lineated quartz veins, at Locality 4. *k*, kink bands; *s*, bedding trace on D_2 cleavage.

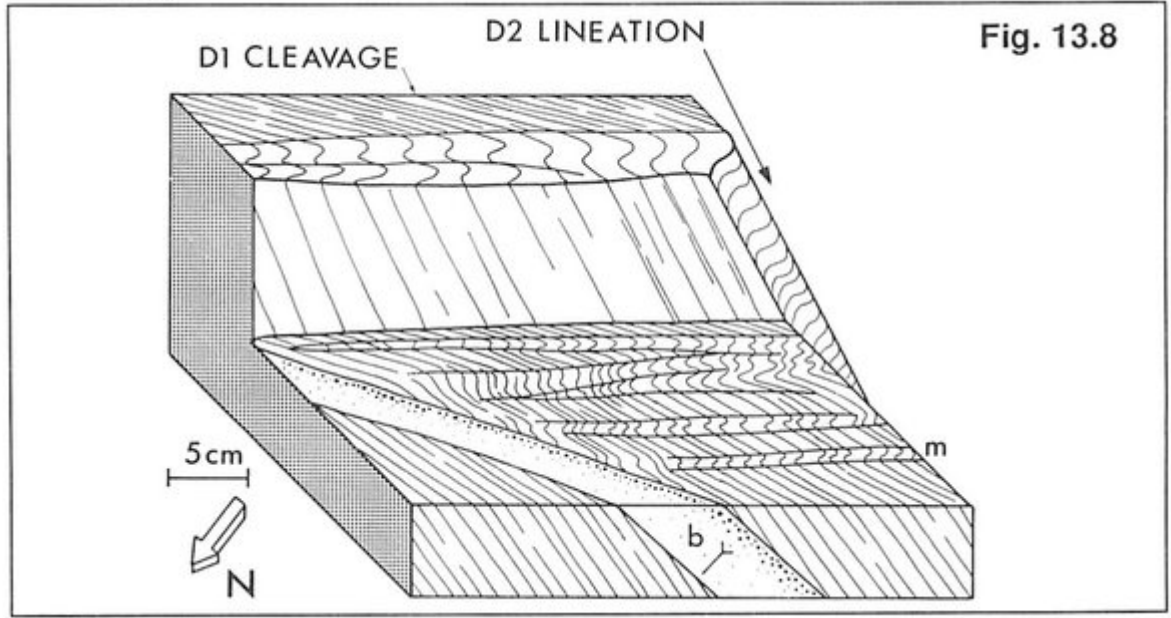

(Figure 13.8) Composite diagram showing the relationships between inverted bedding (*b*), D_1 cleavage and D_2 microlithons (*m*) at Locality 5.

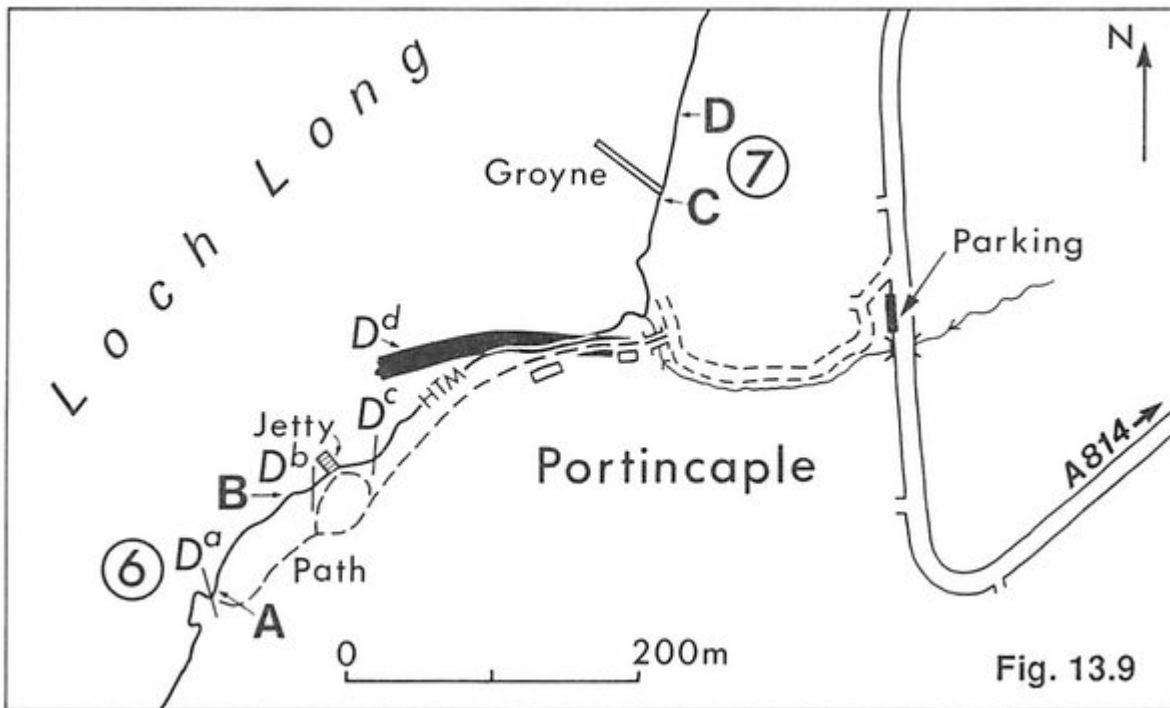

(Figure 13.9) Sketch map showing the location at Portincaple of sections AB (Locality 6), CD (Locality 7) on (Figure 13.10) and of dykes Da-d mentioned in the text.

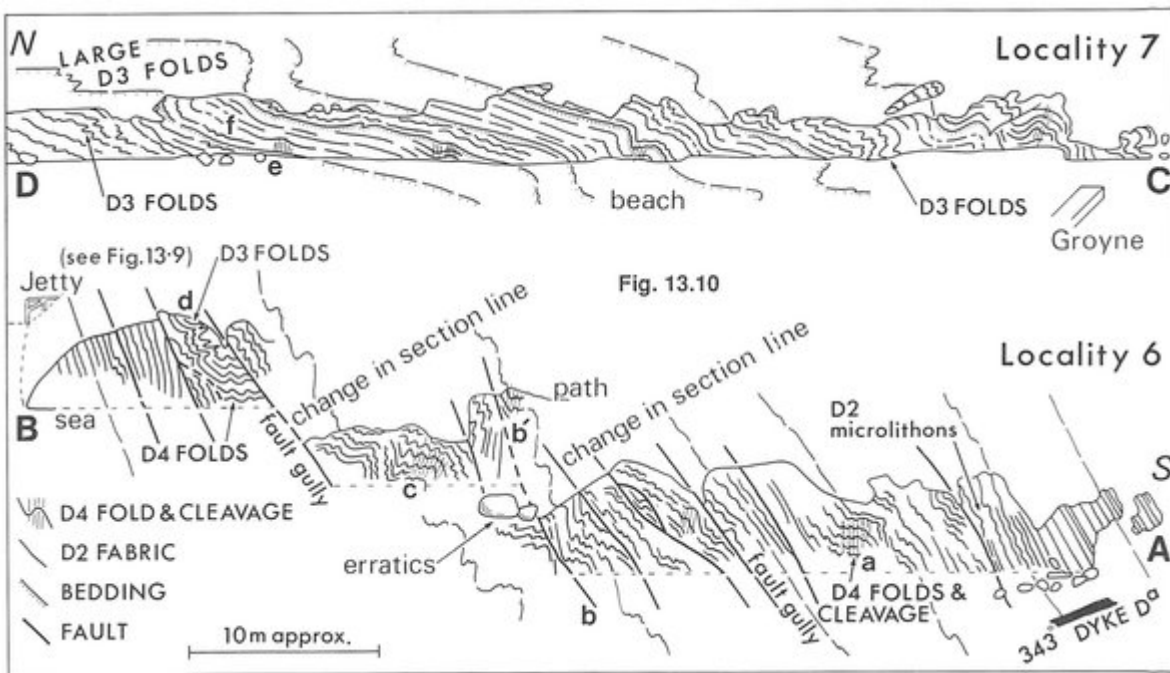

(Figure 13.10) True-scaled N-S sections at Portincaple along lines AB, CD (Localities 6 & 7) on (Figure 13.9) Locations a-f referred to in the text.

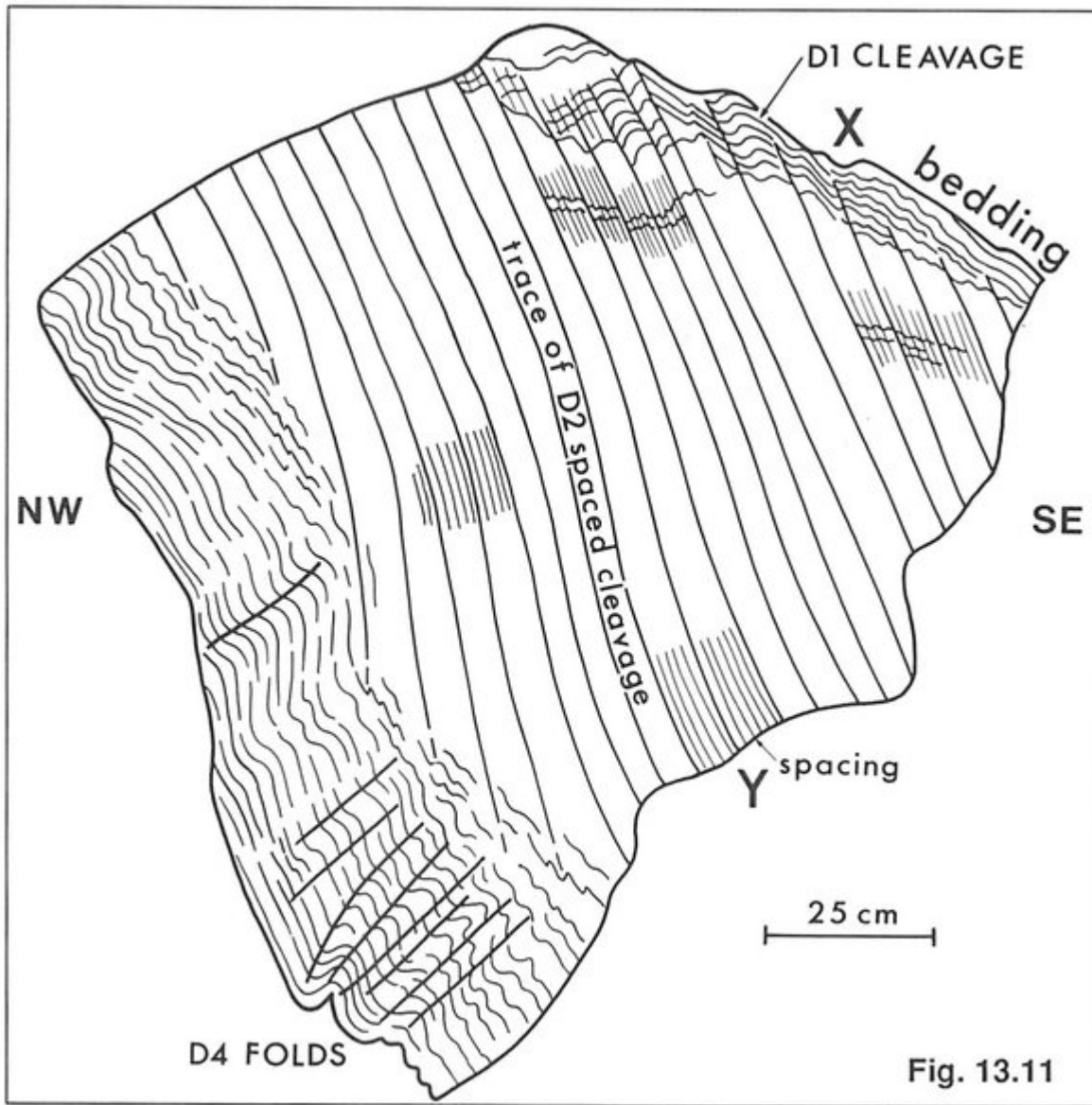

(Figure 13.11) Sketch of the fabrics seen on a flat rock face at location f, (Figure 13.10) at Portincaple. See text for explanation. The convergence of the top right and bottom left sides of the drawing is partly the result of perspective.